

TBD-50 Series Diesel Generator Set

Standby

50 kVA
40 kW

Prime

45 kVA
36 kW



Engine

In Tetra Generator engine products; High performance, low fuel consumption, mechanical or electronic governor depending on the type, Oil, air, fuel filters are interchangeable, using high technology engine brands in accordance with ISO 3046, ISO 8528, BS 5514, DIN 6271 standards.

ENGINE SPECIFICATIONS

Engine Brand	BAUDOIN	
Engine Model	4M06G50/5	
Engine Power	48 kW	
Speed (rpm)	1500 d/dk	
Time	4	
Number of Cylinders	4	
Engine Capacity	2,3 lt	
Bore & Stroke (mmXmm)	89x92	
Compression Ratio	17:1	
Governor Type	Electronic	
Induction System	Turbocharger	
Combustion System	Direct	
Cooling System	Water Cooling	
Lubrication Capacity	15 lt	
Coolant Capacity	20 lt	
Fuel Consumption liter/hour	%100	8 lt
	%75	6 lt
	%50	4 lt

Alternator

In Tetra Generator alternator products, it has a steel body design, robust structure, maintenance-free bearing system (brushless) with self-excitation system, electronic type voltage regulator, BS 4999-5000; CEI EN 60034-1; IEC 60034-1; VDE 0530, OVE M10, NF 51-100, 111; It uses high technology alternator brands in accordance with NEMA MG 1.22.

ALTERNATOR FEATURES

Power Factor	0,8
Insulation Class	H
Protection	IP21-IP23
Output Voltage	231/400 VAC - 50 Hz
Frequency	50 Hz
Connection Type	Star
Design	4 Poles - Brushless

BAUDOUIN Series

Control System

Easy-to-use secure software updates in Tetra Generator control panels have a structure that can be easily done with USB ports. Optionally, remote control can be provided with ETHERNET and GPRS. Panel body is made of steel sheet and is painted with electrostatic powder paint. It has been painted. The electronics are isolated and waterproof design.

CONTROL SYSTEM FEATURES

- LCD Screen Automatic Control System
- Remote monitoring possibility
- Multifunctional business opportunity
- Multi language support
- Programmable over USB, RS-232 and GSM



Chassis, Canopy and Fuel Tank

Tetra Generator chassis has a modular design and is made of steel. Engine alternator Radiator connections are made with vibration wedges and vibration is minimized. Special chassis and fuel tank in line with customer demands can make designs.

CANOPY

- Canopy design that facilitates generator maintenance
- Emergency stop button on the cabin
- Transparent control cabinet window
- Acoustic sponge providing sound insulation
- Hidden exhaust silencer inside the cabin
- Engine cooling air ducts
- Electrostatic powder paint resistant to corrosion and rusting
- Refueling outside the cabin

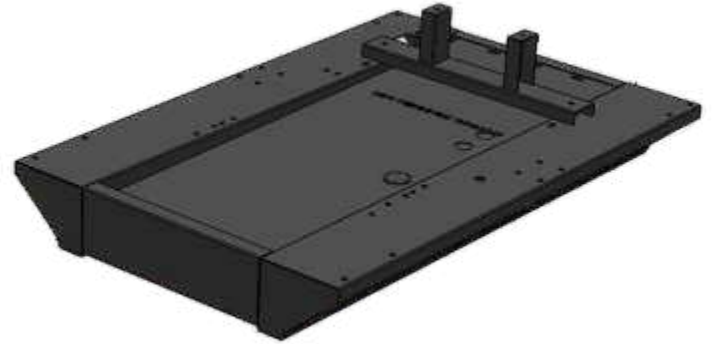

OPTIONS

Transfer Board

Protection Switch

External Type Fuel Tank

Synchronous System

Electronic Governor Application

Earthquake Sensor

Analog Gauges

24 Hour Fuel Tank

Special Chassis Color

Special Cabinet Color

Remote Monitoring Module

Special Type MufLer

Quality Standards

- All generating sets produced by Tetra Generator have TSE, CE and ISO 9001 certificates.
- Technical information and values are in accordance with ISO8528, ISO3046, NEMA MG1.22, IEC 600341, BS 49995000, VDE 0530 standards.

TECHNICAL DIMENSIONS

CABINET GROUP

WIDTH	LENGTH	HEIGHT	WEIGHT	FUEL TANK
1000 mm	2270 mm	1650 mm	935 kg	150 lt

UNCABINET GROUP

WIDTH	LENGTH	HEIGHT	WEIGHT	FUEL TANK
1000 mm	2000 mm	1450 mm	787 kg	150 lt

